

## Veneer flooring industrial style

### Product

Veneer flooring consists of a 0,6mm MOSO bamboo veneer, pressed onto a HDF core, with a soft wood backer. The veneer is pressed cross wise, to create an 'industrial flooring' look. The UNI-CLIC system makes it very easy to install—without using glue.

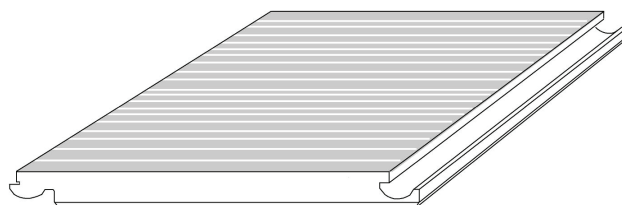

*veneer flooring*

### Product line

Code	Code	Style	Edge	Finish	Dimensions (mm)	Box content (Pcs)	Box content (m <sup>2</sup> )
Natural	Caramel	VL	SE	L	1203x190x8,2	8	2,286
<b>BF-FRPR1000</b>	<b>BF-FRPR1050</b>						

VL = Vertical, industrial look  
SE = Scharp edge  
L = Lacquered

### Installation

Please read the full installation instructions on the backside.

This floor type can be installed – under certain conditions – on warm water floor heating. See “MOSO flooring and floor heating”.

### Technical characteristics

– Domestic usage classification:	EN685: 23
– Commercial usage classification:	EN685: 31
– Resistance to indentation:	EN 1534: $\geq 30$ N/mm <sup>2</sup>
– Resistance to abrasion:	EN 14354: >5000 revolutions
– Thickness distention:	EN 13329 annex G: $\leq 8$
– Density:	950 kg / m <sup>3</sup>
– Fire reaction and smoke generation:	EN 13501: Bfl s1
– Emission Formaldehyde:	<0,124 mg/m <sup>3</sup> (E1-norm)
– Slip resistance:	EN 1339:2003: USRV >15
– Thermal conductivity:	$\lambda = 0,203$ W / (m·K)
– Thermal resistance:	R = 0,0493 m <sup>2</sup> ·K/W



www.moso.eu

# Installation instruction Veneer Flooring

## Before installation

- To allow acclimatisation, lay your bamboo flooring flat in the room in which it is to be installed for at least 48 hours, in its sealed foil packaging or box, at a room temperature of 18°-20°C (50-65% air humidity).
- Please note that the surface to which the flooring is to be applied must have a minimum temperature of 18°C. The flooring may be installed on any sub floor which is level, without cracks, dry, clean and stable.
- Excessive humidity has a detrimental effect on the flooring. Maximum permitted humidity levels for sub floors are: sand cement 1,8%, chipboard 7-9%, anhydrite floors 0.3%.
- We recommend that you use PE damp proof membrane (min 0.2mm). The membrane must overlap by 30 cm.
- We recommend that you use a sound isolating underlay like a PE-foam.

## Please note

- Bamboo is a natural product! Therefore variations in colour and structure within a batch are possible. You should always mix the components from different boxes.
- Before installation, we advise you to inspect the flooring for moisture content, size, colour differences and damage. We cannot accept any complaints regarding this once the material has been installed or further processed.
- Installation of the flooring should always be the final job in any building project, in order to avoid damaging the flooring surface. Take care when working with adhesive tape as this could damage the flooring finish.
- Felt pads must be attached to furniture and chairs to avoid damage to the flooring surface.
- To protect against dust and sand, a walk-off mat has to be placed before and after the entrance of the room.

## Ideal room conditions

- Room temperature approx. 18-20°C; Air humidity 50 - 65%.
- During the winter months, room air can become extremely dry. To maintain a constant air humidity, ceramic humidifiers should be mounted on radiators (or stoves) and, for larger rooms, electric air humidifiers are required. In summer and autumn when air humidity is high, ensure that the room is well-ventilated. Where these conditions are not maintained, warping, shrinkage and movement will occur. Check the air humidity using a hygrometer.

## Expansion gap

- This floor type is laid as a floating floor, see the following installation instructions. Fully glueing the boards to the subfloor is also a possible installation method, but this requires specialist materials and skills; therefore a recognised contractor should carry out the installation.
- Bamboo and wood are natural products which are affected by air humidity. Excessive air humidity causes bamboo materials to swell whilst low air humidity results in shrinking. It is of the utmost importance that you maintain distance (expansion gap) from walls, door frames, pipes etc. This distance should be minimal 10-15 mm. If the floor is wider than approx. 10 metres or longer than approx. 12 metres, a larger expansion gap must be included.

## Floor heating

This floor type can be installed – under certain conditions – on warm water floor heating. Please check the conditions elsewhere in this document.

## Installation

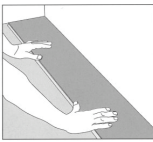
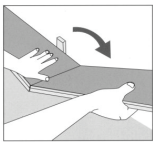
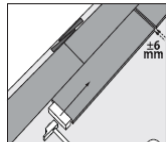
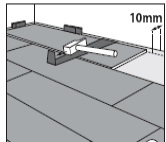
			
<p>1. Place the first board, in the left side of the room, with the tongue side against the wall.</p>	<p>2. Connect the next board on the headside: insert the tongue under a 45 degree angle and press it to the floor. Continue to install the rest of the row in the same manner.</p>	<p>3. Start the second row with the off-cut from the last board installed. Connect it with the first row by clicking it in the length side groove. Place the next board approx 6mm from the first board and use a hammer and tapping block to carefully close the boards on the headside.</p>	<p>4. Continue in this manner until the last row. Remember to leave the above mentioned expansion gap between the floor and the wall.</p>

## Maintenance and cleaning

Cleaning and care: The useful life of your engineered boards will be considerably increased with suitable cleaning and maintenance. Ask your supplier which products are suitable.

## Skirting boards

Skirting boards must be fixed to the walls with screws and plugs in such a way as not to obstruct the natural movement of the wooden floor. If skirting boards are fixed to the wooden floor they will obstruct the floor's natural movement, and may, therefore, cause damage.

## Additional note

Whilst all due care is taken to ensure the accuracy of the installation instructions, individual circumstances (location, subfloor and installation procedures) may vary and are beyond the manufacturer's control. In case of doubt, therefore, consult the distributor.